

FIG. 1

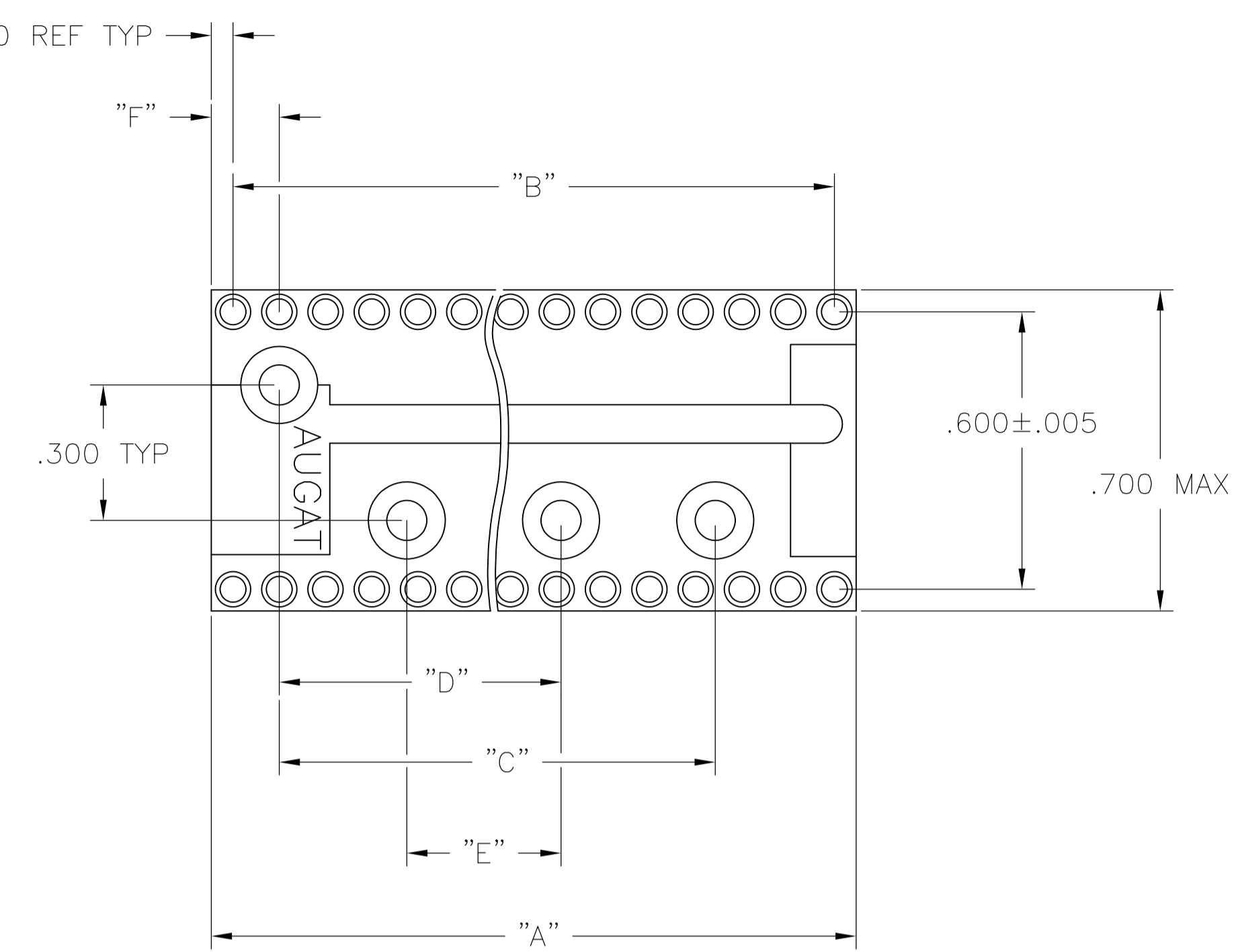

FIG. 2

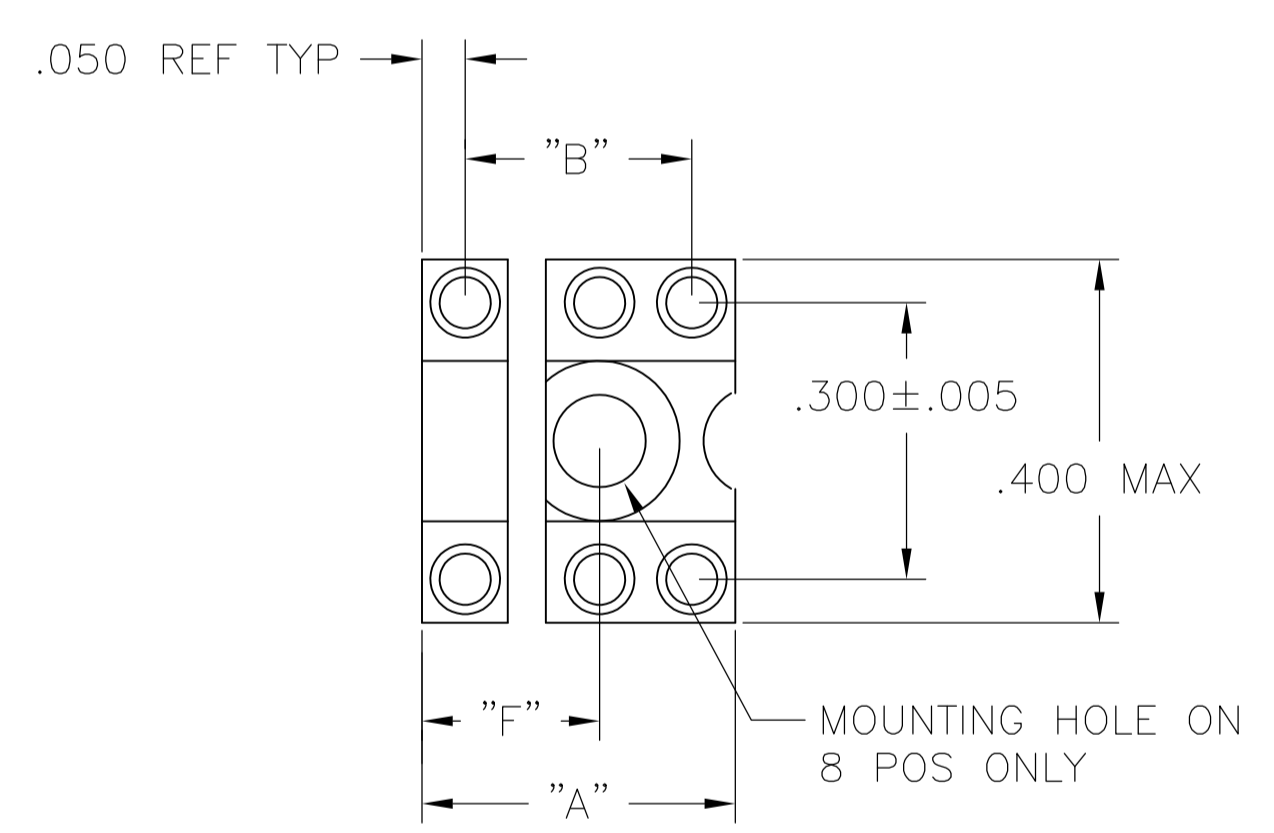

FIG. 3

6 POS MOUNTING HOLE OMITTED

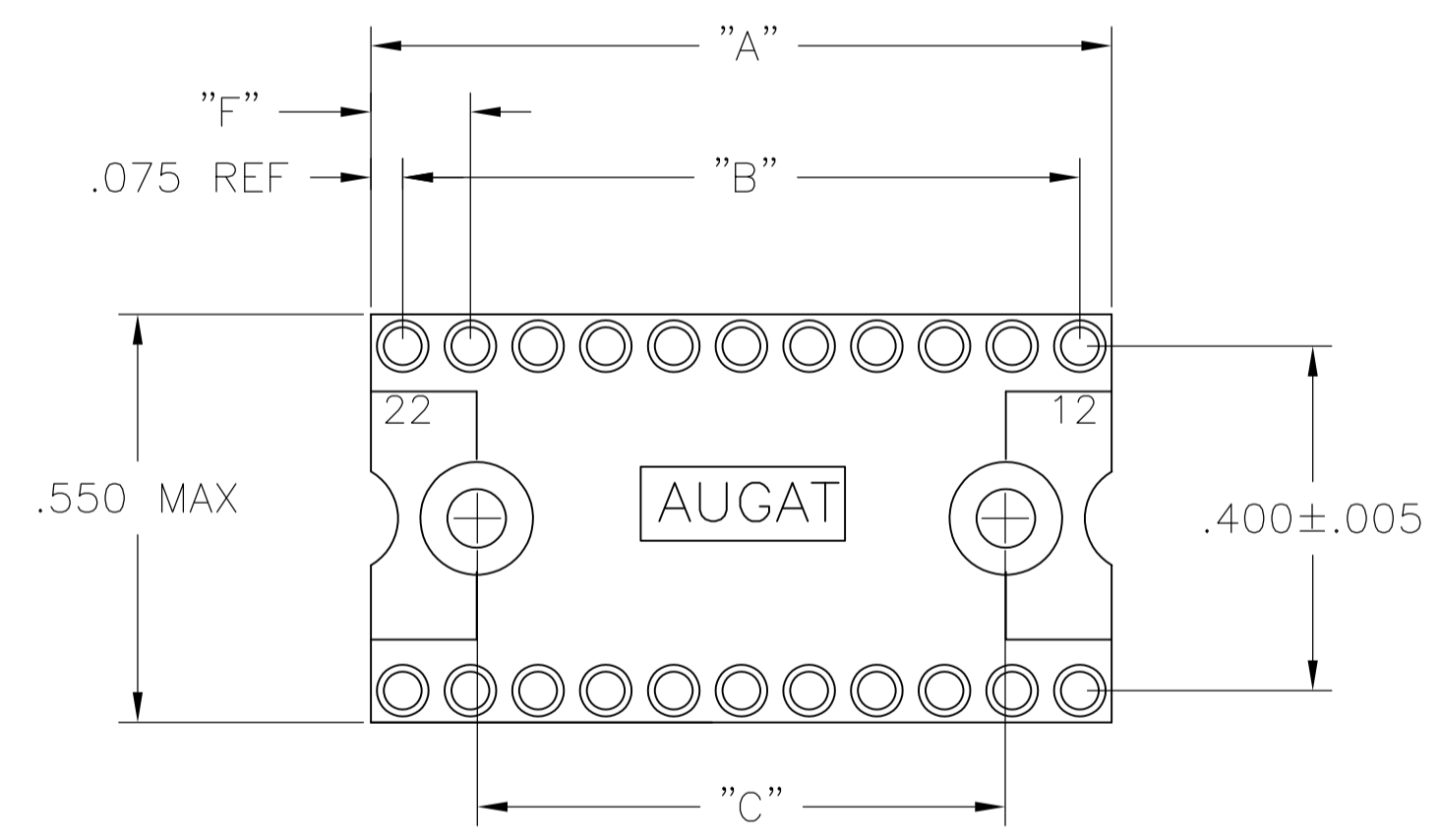
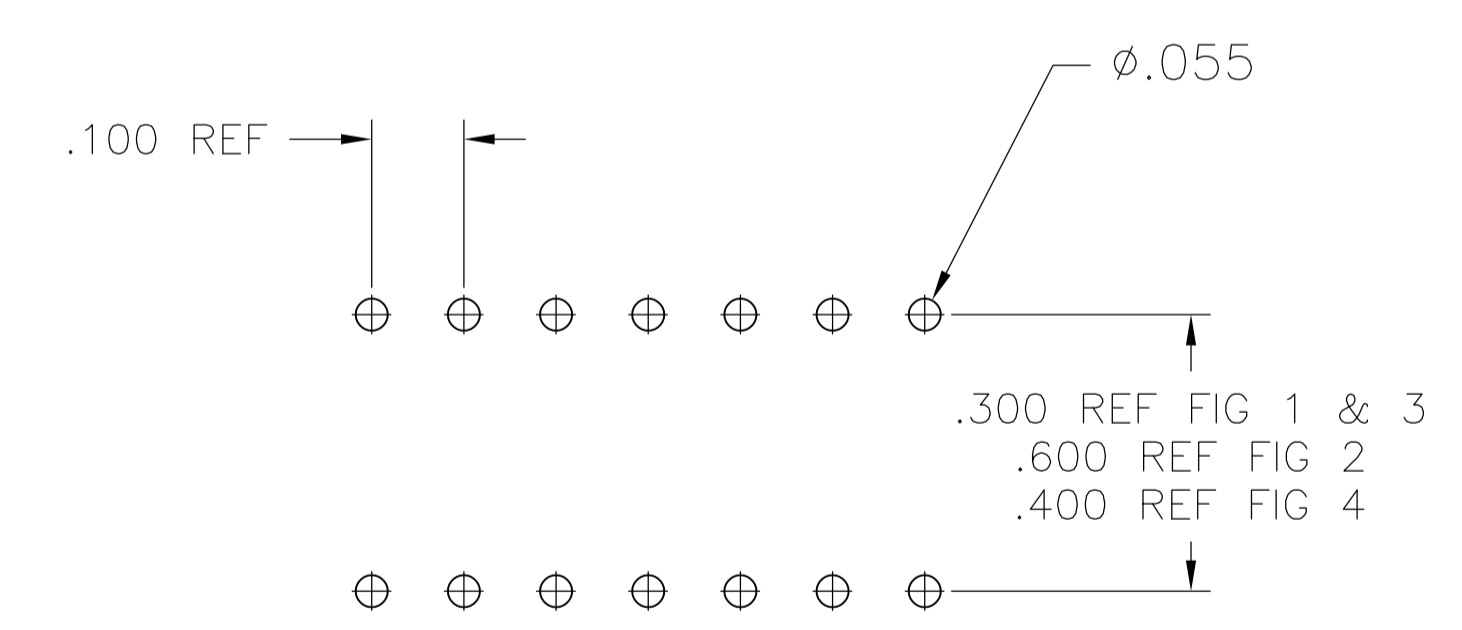
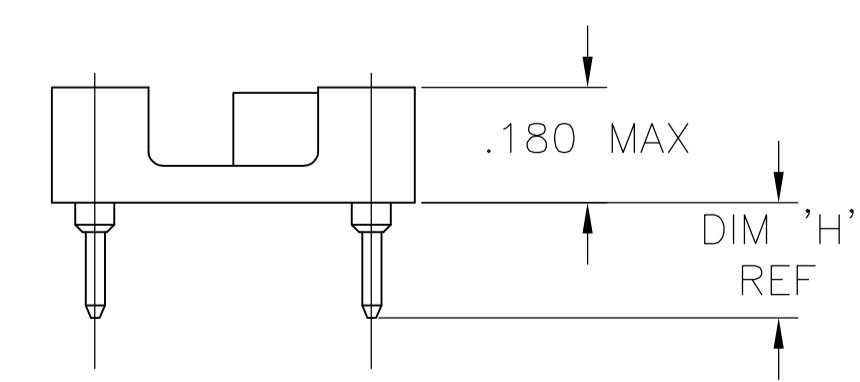
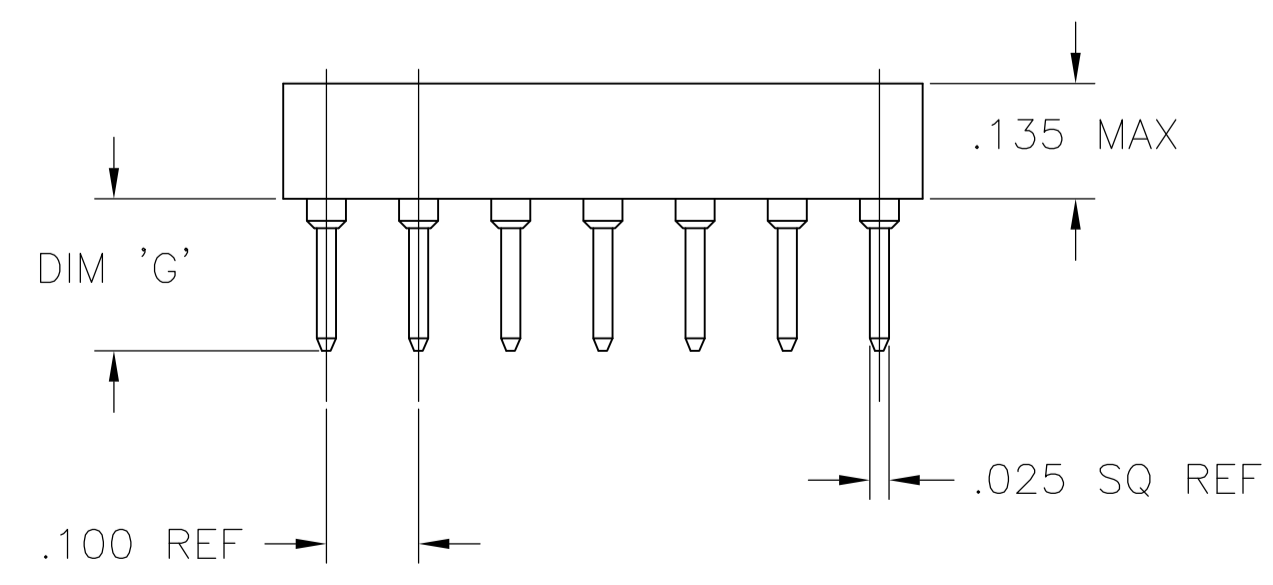

FIG. 4



P.C.B. HOLE LAYOUT  
TOLERANCE ±.003



- 1 INSULATOR MATERIAL - THERMOPLASTIC POLYESTER, PCT, BLACK, UL94 V-0.
- 2 CONTACT - 4 BEAM, BECU, MACHINED (PREMIUM) OR STAMPED (ECONOMY, W/SUFFIX -ES OR -ESL)
- 3 SLEEVE - MACHINED COPPER ALLOY.
- 4 PLATING: CONTACT -20 μIN MIN. GOLD OVER 30 μIN MIN NICKEL  
SLEEVE -7.5 μIN MIN. GOLD OVER 50 μIN MIN NICKEL
- 5 PLATING: CONTACT -20 μIN MIN. GOLD OVER 30 μIN MIN NICKEL  
SLEEVE -80 μIN MIN. TIN-LEAD OVER 50 μIN MIN COPPER
- 6 PLATING: CONTACT -20 μIN MIN. GOLD OVER 30 μIN MIN NICKEL  
SLEEVE -180 μIN MIN. TIN-LEAD OVER 50 μIN MIN COPPER
- 7 PLATING: CONTACT -80 μIN MIN. TIN-LEAD OVER 75 μIN MIN COPPER  
SLEEVE -80 μIN MIN. TIN-LEAD OVER 50 μIN MIN COPPER
- 8 PLATING: CONTACT -80 μIN MIN. TIN-LEAD OVER 75 μIN MIN COPPER  
SLEEVE -180 μIN MIN. TIN-LEAD OVER 50 μIN MIN COPPER
- 9 PLATING: CONTACT -5 μIN MIN. GOLD OVER 50 μIN MIN NICKEL  
SLEEVE -7.5 μIN MIN. GOLD OVER 50 μIN MIN NICKEL
- 10 PLATING: CONTACT -5 μIN MIN. GOLD OVER 50 μIN MIN NICKEL  
SLEEVE -80 μIN MIN. TIN-LEAD OVER 50 μIN MIN COPPER
- 11 PLATING: CONTACT -5 μIN MIN. GOLD OVER 50 μIN MIN NICKEL  
SLEEVE -180 μIN MIN. TIN-LEAD OVER 50 μIN MIN COPPER

ELECTRICAL:

CONTACT RESISTANCE: 10 MILLIOHMS MAX  
 CONTACT RATING: 3 AMPS  
 CAPACITANCE: 1.0 pF PER MIL-STD-202, METHOD 305  
 INSULATION RESISTANCE: 5000 MOHMS MIN @ 500 VDC PER EIA-364-21  
 DIELECTRIC WITHSTANDING VOLTAGE: 1000 VOLTS (RMS) PER EIA-364-20

MECHANICAL:

AFTER INSERTION FORCE:  
 134 GRAMS AVG (4 BEAM PREMIUM) 179 GRAMS AVG (4 BEAM ECONOMY)  
 AFTER WITHDRAWAL FORCE:  
 63 GRAMS AVG (4 BEAM PREMIUM OR ECONOMY)

ENVIRONMENTAL:

OPERATING TEMPERATURE: -55°C TO -105°C

SEE SHEETS 2 & 3 FOR PART NUMBER TABLES

THIS DRAWING IS A CONTROLLED DOCUMENT.		DIN	BSV	-
DIMENSIONS: INCHES		CHK	K. WRIGHT	-
TOLERANCES UNLESS OTHERWISE SPECIFIED:		APP'D	K. WRIGHT	-
0 PLC	± -	PRODUCT SPEC		
1 PLC	± -	APPLICATION SPEC		
2 PLC	± -	WEIGHT		
3 PLC	± .005	SIZE	A1	00779
4 PLC	± -	CAGE CODE	1437532	
ANGLES	± -	DRAWING NO	1437532	
FINISH	-	RESTRICTED TO		
MATERIAL		CUSTOMER DRAWING	SCALE	4:1
		SHEET	1	OF 3
		REV	01	

OBSOLETE  
 SUPERCEDED BY 7-1437532-0

OBSOLETE  
 SUPERCEDED BY 5-1437532-9

OBSOLETE  
 SUPERCEDED BY 8-1437531-7

OBSOLETE  
 SUPERCEDED BY 4-1437531-9

OBSOLETE  
 SUPERCEDED BY 2-1437531-5

7	2	.510	.595/.565	.150	.500	.900	1.500	1.900	2.000	40	6-1437534-9
6	2	.370	.455/.425	.150	.500	.900	1.500	1.900	2.000	40	7-1437534-0
5	2	.510	.595/.565	.150	.500	.900	1.500	1.900	2.000	40	8-1437532-2
4	2	.370	.455/.425	.150	.500	.900	1.500	1.900	2.000	40	7-1437532-9
4	2	.510	.595/.565	.150	.500	.900	1.500	1.900	2.000	40	7-1437532-8
7	2	.510	.595/.565	.150	.500	.900	1.500	1.700	1.800	36	7-1437532-3
5	2	.510	.595/.565	.150	.500	.900	1.500	1.700	1.800	36	7-1437833-0
4	2	.510	.595/.565	.150	.500	.900	1.500	1.700	1.800	36	7-1437532-0
6	2	.370	.455/.425	.150	-	.400	.900	1.500	1.600	32	6-1437532-4
5	2	.510	.595/.565	.150	-	.400	.900	1.500	1.600	32	6-1437532-3
4	2	.370	.455/.425	.150	-	.400	.900	1.500	1.600	32	6-1447289-3
4	2	.510	.595/.565	.150	-	.400	.900	1.500	1.600	32	5-1437532-9
7	2	.510	.595/.565	.150	-	.400	.900	1.300	1.400	28	5-1437534-3
6	2	.370	.455/.425	.150	-	.400	.900	1.300	1.400	28	4-1437532-0
5	2	.510	.595/.565	.150	-	.400	.900	1.300	1.400	28	3-1437532-9
4	2	.510	.595/.565	.150	-	.400	.900	1.300	1.400	28	3-1437532-4
5	4	.510	.595/.565	.150	-	-	.900	1.100	1.200	24	2-1437532-6
4	4	.510	.595/.565	.150	-	-	.900	1.100	1.200	24	2-1437532-4
7	2	.510	.595/.565	.150	-	.400	.900	1.100	1.200	24	1-1437532-8
6	2	.370	.455/.425	.150	-	.400	.900	1.100	1.200	24	1-1437532-6
5	2	.510	.595/.565	.150	-	.400	.900	1.100	1.200	24	1-1437532-5
4	2	.370	.455/.425	.150	-	.400	.900	1.100	1.200	24	1-1437532-2
4	2	.510	.595/.565	.150	-	.400	.900	1.100	1.200	24	1-1437532-1
7	1	.510	.595/.565	.175	-	-	.800	1.000	1.150	22	1437532-4
5	1	.510	.595/.565	.175	-	-	.800	1.000	1.150	22	4-1437534-9
4	1	.510	.595/.565	.175	-	-	.800	1.000	1.150	22	1437532-1
8	1	.370	.455/.425	.250	-	-	.500	.900	1.000	20	8-1437531-8
7	1	.510	.595/.565	.250	-	-	.500	.900	1.000	20	8-1437531-7
6	1	.370	.455/.425	.250	-	-	.500	.900	1.000	20	8-1437531-5
5	1	.510	.595/.565	.250	-	-	.500	.900	1.000	20	8-1437531-4
4	1	.370	.455/.425	.250	-	-	.500	.900	1.000	20	8-1437531-1
4	1	.510	.595/.565	.250	-	-	.500	.900	1.000	20	8-1437531-0
6	1	.370	.455/.425	.150	-	-	.600	.800	.900	18	7-1437531-2
5	1	.510	.595/.565	.150	-	-	.600	.800	.900	18	7-1437531-1
4	1	.510	.595/.565	.150	-	-	.600	.800	.900	18	6-1437531-6
8	1	.370	.455/.425	.150	-	-	.500	.700	.800	16	5-1437531-0
7	1	.510	.595/.565	.150	-	-	.500	.700	.800	16	4-1437531-9
6	1	.370	.455/.425	.150	-	-	.500	.700	.800	16	4-1437531-6
5	1	.510	.595/.565	.150	-	-	.500	.700	.800	16	4-1437531-5
4	1	.370	.455/.425	.150	-	-	.500	.700	.800	16	4-1437531-2
4	1	.510	.595/.565	.150	-	-	.500	.700	.800	16	4-1437531-1
8	1	.370	.455/.425	.150	-	-	.400	.600	.700	14	2-1437531-6
7	1	.510	.595/.565	.150	-	-	.400	.600	.700	14	2-1437531-5
6	1	.370	.455/.425	.150	-	-	.400	.600	.700	14	2-1437531-3
5	1	.510	.595/.565	.150	-	-	.400	.600	.700	14	2-1437531-2
4	1	.370	.455/.425	.150	-	-	.400	.600	.700	14	1-1437531-9
4	1	.510	.595/.565	.150	-	-	.400	.600	.700	14	1-1437531-8
7	3	.510	.595/.565	.200	-	-	-	.300	.400	8	8-1437529-4
6	3	.370	.455/.425	.200	-	-	-	.300	.400	8	8-1437529-2
5	3	.510	.595/.565	.200	-	-	-	.300	.400	8	8-1437529-1
4	3	.370	.455/.425	.200	-	-	-	.300	.400	8	7-1437529-7
4	3	.510	.595/.565	.200	-	-	-	.300	.400	8	7-1437529-6
6	3	.370	.455/.425	-	-	-	-	.200	.300	6	7-1437529-0
5	3	.510	.595/.565	-	-	-	-	.200	.300	6	6-1437529-9
4	3	.510	.595/.565	-	-	-	-	.200	.300	6	6-1437529-6

FINISH	FIG	H	G	F	E	D	C	B	"A" MAX	NO. OF POSN	PART NO.
--------	-----	---	---	---	---	---	---	---	---------	-------------	----------

PREMIUM VERSION PART NUMBERS

SEE SHEET 3 FOR ECONOMY VERSION PART NUMBERS

THIS DRAWING IS A CONTROLLED DOCUMENT.

DIMENSIONS: INCHES

TOLERANCES UNLESS OTHERWISE SPECIFIED:

0. PLC	± .005
1. PLC	± .005
2. PLC	± .005
3. PLC	± .005
4. PLC	± .005
ANGLES	± .005

MATERIAL: - FINISH: -

DWN: BSV -  
 CHK: K. WRIGHT -  
 APVD: K. WRIGHT -  
 NAME: -  
 PRODUCT SPEC: -  
 APPLICATION SPEC: -  
 WEIGHT: -  
 CUSTOMER DRAWING

TE Connectivity

CLOSED FRAME DIP, PREMIUM LEAD FREE (REF AUGAT 500 SERIES) PREMIUM (MACHINED CONTACT)

SIZE: A1 CASE CODE: 00779 DRAWING NO: 1437532 RESTRICTED TO: -  
 SCALE: 4:1 SHEET 2 OF 3 REV 01

SUPERCEDED BY 8-1437532-2	$\frac{10}{5}$	2	.510	.595/.565	.150	.500	.900	1.500	1.900	2.000	40	7-1437536-8
SUPERCEDED BY 8-1437532-2	$\frac{5}{5}$	2	.510	.595/.565	.150	.500	.900	1.500	1.900	2.000	40	7-1437536-7
SUPERCEDED BY 6-1437532-3	$\frac{10}{5}$	2	.510	.595/.565	.150	-	.400	.900	1.500	1.600	32	6-1437536-7
SUPERCEDED BY 6-1437532-3	$\frac{5}{5}$	2	.510	.595/.565	.150	-	.400	.900	1.500	1.600	32	6-1437536-6
SUPERCEDED BY 3-1437532-9	$\frac{10}{5}$	2	.510	.595/.565	.150	-	.400	.900	1.300	1.400	28	5-1437536-9
SUPERCEDED BY 3-1437532-9	$\frac{5}{5}$	2	.510	.595/.565	.150	-	.400	.900	1.300	1.400	28	5-1437536-8
SUPERCEDED BY 3-1437532-4	$\frac{4}{4}$	2	.510	.595/.565	.150	-	.400	.900	1.300	1.400	28	5-1437536-4
SUPERCEDED BY 2-1437532-6	$\frac{10}{10}$	4	.510	.595/.565	.150	-	.400	.900	1.100	1.200	24	5-1437536-1
SUPERCEDED BY 1-1437532-5	$\frac{10}{5}$	2	.510	.595/.565	.150	-	.400	.900	1.100	1.200	24	4-1437536-4
SUPERCEDED BY 1-1437532-5	$\frac{5}{5}$	2	.510	.595/.565	.150	-	.400	.900	1.100	1.200	24	4-1437536-3
SUPERCEDED BY 4-1437534-9	$\frac{5}{5}$	1	.510	.595/.565	.175	-	-	.800	1.000	1.150	22	3-1437536-6
SUPERCEDED BY 8-1437531-4	$\frac{10}{5}$	1	.510	.595/.565	.250	-	-	.500	.900	1.000	20	2-1437536-9
SUPERCEDED BY 8-1437531-4	$\frac{5}{5}$	1	.510	.595/.565	.250	-	-	.500	.900	1.000	20	2-1437536-8
SUPERCEDED BY 8-1437531-0	$\frac{4}{4}$	1	.510	.595/.565	.250	-	-	.500	.900	1.000	20	2-1437536-4
SUPERCEDED BY 7-1437531-1	$\frac{10}{5}$	1	.510	.595/.565	.150	-	-	.600	.800	.900	18	1-1437536-8
SUPERCEDED BY 7-1437531-1	$\frac{5}{5}$	1	.510	.595/.565	.150	-	-	.600	.800	.900	18	1-1437536-7
SUPERCEDED BY 6-1437531-6	$\frac{4}{4}$	1	.510	.595/.565	.150	-	-	.600	.800	.900	18	6-1437531-7
SUPERCEDED BY 4-1437531-5	$\frac{10}{5}$	1	.510	.595/.565	.150	-	-	.500	.700	.800	16	4-1437531-7
SUPERCEDED BY 4-1437531-5	$\frac{5}{5}$	1	.510	.595/.565	.150	-	-	.500	.700	.800	16	1437536-9
SUPERCEDED BY 4-1437531-6	$\frac{6}{6}$	1	.370	.455/.425	.150	-	-	.500	.700	.800	16	1437536-8
SUPERCEDED BY 4-1437531-1	$\frac{4}{4}$	1	.510	.595/.565	.150	-	-	.500	.700	.800	16	1437536-4
SUPERCEDED BY 2-1437531-2	$\frac{10}{5}$	1	.510	.595/.565	.150	-	-	.400	.600	.700	14	9-1437535-6
SUPERCEDED BY 2-1437531-2	$\frac{5}{5}$	1	.510	.595/.565	.150	-	-	.400	.600	.700	14	9-1437535-5
SUPERCEDED BY 1-1437531-8	$\frac{4}{4}$	1	.510	.595/.565	.150	-	-	.400	.600	.700	14	9-1437535-2
SUPERCEDED BY 8-1437529-1	$\frac{10}{5}$	3	.510	.595/.565	.200	-	-	.300	.400	.400	8	1-1437535-7
SUPERCEDED BY 8-1437529-1	$\frac{5}{5}$	3	.510	.595/.565	.200	-	-	.300	.400	.400	8	1-1437535-6
SUPERCEDED BY 6-1437529-9	$\frac{10}{10}$	3	.510	.595/.565	-	-	-	.200	.300	.300	6	1-1437535-0
SUPERCEDED BY 6-1437529-6	$\frac{4}{4}$	3	.510	.595/.565	-	-	-	.200	.300	.300	6	6-1437529-7

FINISH	FIG	H	G	F	E	D	C	B	"A" MAX	NO. OF POSN	PART NO.
--------	-----	---	---	---	---	---	---	---	---------	-------------	----------

ECONOMY VERSION PART NUMBERS

SEE SHEET 2 FOR PREMIUM VERSION PART NUMBERS

THIS DRAWING IS A CONTROLLED DOCUMENT.		DIN	BSV	-	 TE Connectivity
DIMENSIONS: INCHES		CIR	K. WRIGHT	-	
TOLERANCES UNLESS OTHERWISE SPECIFIED:		APVD	K. WRIGHT	-	NAME
0. PLC	± .005	PRODUCT SPEC	CLOSED FRAME DIP, PREMIUM LEAD FREE (REF AUGAT 500 SERIES) PREMIUM (MACHINED CONTACT)		
1. PLC	± .005	APPLICATION SPEC	SIZE	CAGE CODE	DRAWING NO
2. PLC	± .005		A1	00779	1437532
3. PLC	± .005		WEIGHT	-	
4. PLC	± .005		CUSTOMER DRAWING		
ANGLES	± .005		SCALE	4:1	SHEET 3 OF 3
			REV	01	